

防冲板 Steel Frontal Panel

防冲板的主要作用是承受靠泊力，分散护舷反力对船体的作用力，降低面压。一般分为开放式结构和封闭式结构。开放式结构一般有面板、工字纵梁和横梁等组成。封闭式防冲板一般有面板和背板、工字梁和横梁等组成。

防冲板结构应根据码头结构、护舷布置、水文条件等多种因素综合考虑进行设计，设计时可与我公司设计部门联系。

The main function of frontal panel is to distribute the reaction forces from fender units into the ship's hull. There are two types: open type and closed type. Regarding the open type, it is consist of steel pad, H steel and across steel. Closed type are consist of steel pad and back steel, H steel.

The structure of frontal panel should be designed according to ships, dock structures, fender arrangement and water condition, etc. please contact our Technology Dept for details.

防冲板面压计算:

Frontal panel surface pressure calculating:

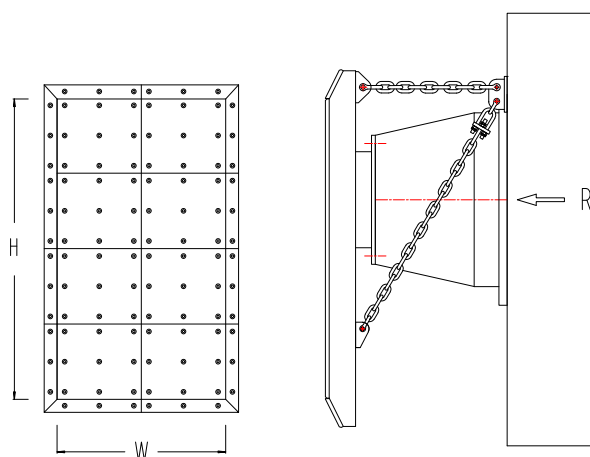

$$\frac{\sum R}{W \times H} \leq P_h$$

P -面压 Hull pressure (KN/m²)

ΣR -安装护舷的反力之和 Combined reaction of all rubber fenders

W -防冲板接触面宽度(不含斜面) Panel width excluding lead-in chamfers

H -防冲板接触面长度(不含斜面) Panel height excluding lead-in chamfers

P_h -最大允许面压 Permissible hull pressure (KN/m²)

船型 Vessel type	规格/等级 Size/class	面压 Hull pressure (kN/m ²)
集装箱船 Container ships	< 1 000 teu (1st/2nd generation)	< 400
	< 3 000 teu (3rd generation)	< 300
	< 8 000 teu (4th generation)	< 250
		< 200
普通货船 General cargo	≤ 20 000 DWT	400-700
	> 20 000 DWT	< 400
油轮 Oil tankers	≤ 20 000 DWT	< 250
	≤ 60 000 DWT	< 300
巨型原油船 VLCC/ULCC	> 60 000 DWT	150-200
液化气船 Gas carriers	LNG/LPG	< 200
散货船 Bulk carriers		< 200
滚装船 RoRo 客船/邮轮 Passenger/cruise 双体船 SWATH		通常具有装甲带 Usually fitted with beltings (strakes)

防冲板钢材要求:

PIANC steel thicknesses:

根据行业规范, 防冲板所选钢板的厚度, 需满足右边表格的需求:

PIANC recommends the following minimum steel thicknesses for fender panel construction:

双面暴露 Exposed both faces	≥12mm
单面暴露 Exposed one face	≥10mm
内部钢板 Internal (not exposed)	≥8mm

典型防冲板重量:

右表是防冲板最小平均重量的参考, 不含PE板:
The table can be used as a guide to minimum average panel weight (excluding UHMW-PE face pads) for different service conditions:

轻型 Light duty	200-250kg/m ²
中型 Medium duty	250-300kg/m ²
重型 Heavy duty	300-400kg/m ²
超重型 Extreme duty	≥400kg/m ²

防腐处理 Corrosion Prevention

防冲板防腐目前主要采用喷漆、镀锌等工艺方法, 根据码头的使用要求、水文条件等可选择不同的防腐方法。喷漆目前主要采用环氧漆、聚氨酯漆等。

ISO EN 12944国际标准中详细说明了各种环境下的防腐措施。C5-M等级可适用于高盐、近海的环境, 满足护舷系统的一般防腐需求, 下表中包含C5-M等级的操作程序:

The corrosion prevention of steel frontal panel now adopt hot zinc spraying and painting etc, which is subject to port requirement. Painting includes epoxy paint and polyurethane etc.

ISO EN 12944 is a widely used international standard defining the durability of corrosion protection systems in various environments. The C5-M class applies to marine coastal and high salinity locations and is considered to be the most applicable to fenders.

The table gives some typical C5-M class paint systems:

喷漆规程 Paint	表面处理 Surface	底漆喷涂 Priming Coat(s)				面漆喷涂 Top Coats			合计 Paint System		预期防腐年限 Expected durability
		粘结剂	底漆	漆层	NDFT	粘结剂	漆层	NDFT	漆层	NDFT	
S7.09	Sa2.5	EP,PUR	Zn(R)	1	40	EP,PUR	3-4	280	4-5	320	>15y (年)
S7.11	Sa2.5	EP,PUR	Zn(R)	1	40	EP,PUR	3	360	4	400	>15y (年)
											5-15y (年)

Sa 2.5 is defined in ISO 8501-1

喷漆标准可以参考国际标准

NDFT = Nominal dry film thickness.

标称总干膜厚度

Zn (R) = Zinc rich prime 富锌底漆

Misc = miscellaneous types of

anticorrosive pigments. 复配防腐漆

EP = 2-pack epoxy

双组分环氧树脂漆

PUR = 1-pack or 2-pack polyurethane

单组份或双组分聚氨酯漆

CTE = 2-pack coal tar epoxy

双组分环氧沥青漆

参考因素 considerations

1. 最小干膜厚度 >80% of NDFT (典型值)
2. 最大干膜厚度 <3 × NDFT (典型值)
3. 适用的操作温度, 干燥及操作时间
4. 当地环境条件: 温度, 湿度, 污染物等

1. Minimum dry film thickness >80% of NDFT (typical)
2. Maximum film thickness <3 × NDFT (typical)
3. Application temperatures, drying and handling times
4. Local conditions including humidity or contaminants.